



Piezo Film Sensors

Product Guide and Price List

Measurement Specialties, Inc.

15 MAY 01

Handling charge for orders < SFr. 200.00 might be applied. Please ask.

TYPICAL APPLICATIONS FOR PIEZO FILM SENSORS

Accelerometer

- ACH-01 (General Purpose)
 - Car Alarm
 - Shipping Damage
 - Machinery Monitoring
 - Motional Feedback for Speakers
 - Security Sensing
 - Appliance Monitoring
- ACH04-08 (Multi-Axis)
 - Disc Drive Shock Sensing
 - Impact Switching
 - Biomedical Monitoring
- Shockwriter 3000
 - Shipping Damage
 - Materials Handling
 - Machinery Monitoring

Vibration/Motion Film Sensor

- DT Series (Unlaminated, Unshielded)
 - Dynamic Strain Gages
 - Acoustic Pickups
 - Musical Instrument Triggers
 - Tamper Detection
- LDT Series (Laminated, Unshielded)
 - Antitheft Alarm
 - Vending
 - Dispensing Verification
 - Coin Drop Counters
 - Antitamper
 - Penetration Panels
 - Fan Failure
 - Appliance Monitoring
 - Washer Imbalance
 - Microwave - Sound Pickup
 - Dishwasher Spray Arm
 - Water Flow Sensor
 - Vacuum Soil Sensing
- SDT Series (Unlaminated, Shielded)
 - Musical Instrument Triggers
 - Contact Microphones
- Custom Sensors
 - Textile Sensors
 - Thread Break/Tension
 - Medical Monitoring
 - Patient Bed Monitor
 - Pulse Counter
 - Fetal Heart Monitor
 - Apnea Monitoring
 - Anesthesia Monitor (Sleep Disorder)
 - Respiratory Air Flow
 - Sleep Disorder (REM)
 - Pacemaker Activity Monitor
 - Earthquake Alarm

Power Supply

- Alternate Energy

Switch

- SW100 Series
 - Pinball Impact Switches
 - Gaming Machine Switches
 - Utility Meter Counters
- Custom Switches
 - Vector Switch/Joystick
 - CMOS Circuit Wake-up Switch
 - Pacinko Game
 - Electronic Piano Keys
 - Impact Printer Timing Switch
 - Sports Scoring
 - Karate Boxing Force
 - Dartboard Scoring
 - Snap Action Switches
 - Beam Switch

Ultrasound

- Air-Ranging Proximity
- Medical Imaging Catheters
- Phased Array
- Non Destructive Testing
- Acoustic Emission
- Shockwave Sensors
- Level Sensors (Inkjet, toner)
- Robotic Tactile Sensors
- Variable Force Sensors

Audio/Acoustic

- Microphones
 - Dive Helmets
 - Gas Mask
 - Contact
- Acoustic Pickups
- Flow Sensors
- Speakers
 - Novelty Consumer
 - Tweeters
 - Pagers
- Hydrophones
 - Navy SONAR
 - Geophysical SONAR
- Active Vibration Damping/Noise

Traffic Sensors

- Series BL
 - Vehicle Classification
 - Weight-in-Motion
 - Speed/Red Light Enforcement
 - Airport Taxiway
 - Security/Safety

Piezo Cable

- Step Switches
- Pedestrian Mats
- Perimeter Security
- Antitamper

Metallized Piezo Film Sheets

Piezo film is available in a variety of different film sizes and thicknesses. These can be fabricated into simple transducers, or for use as full size sheets for applications such as speakers.

Metallization options include a compliant silver ink as well as sputtered metallization. The silver ink is best for applications where mechanical stress is being applied to the film. Thin sputtered metallization is brittle, and used where signal to noise requirements dictate very low mass loading by the electrodes. These are only general rules, and a discussion with our applications engineers will help you to make the best choice for your specific application.

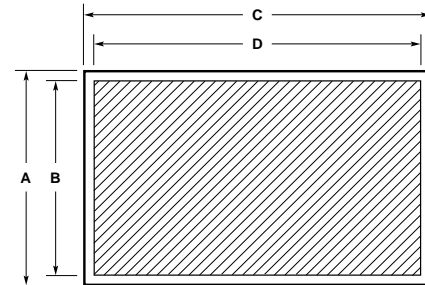

Silver ink lends itself to custom metallization patterns for easy lead attachment. Our standard sputtered metallization is a nickel copper alloy, which has good conductivity and is resistant to oxidation. Other metallizations such as gold are available on a custom basis with a set up fee.

Piezo Film is available in different thicknesses. Thinner films (28 and 52 μm) are the most common, due to their higher capacitance and good mechanical qualities. Thicker film (110 μm) is used where maximum robustness is needed, or if the sensor is being used in a thickness mode (d_{33}) application.

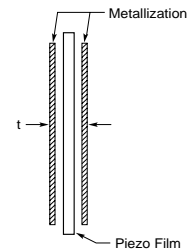

Description	DIMENSIONS in INCHES (mm)							Low Volume Price (SFr)
	A Film	B Electrode	C Film	D Electrode	t (μm)	Metallization	Part #	
28 μm piezo film	8.00 (203.00)	7.50 (190.00)	5.50 (140.00)	5.00 (127.00)	28	NiCu Alloy	1-1003703-4	Fr. 109.00
28 μm piezo film	8.00 (203.00)	7.50 (190.00)	11.00 (280.00)	10.50 (267.00)	28	NiCu Alloy	1-1003702-4	Fr. 217.00
28 μm piezo film	8.00 (203.00)	7.50 (190.00)	5.50 (140.00)	5.00 (127.00)	40	Silver Ink	1-1004347-0	Fr. 109.00
28 μm piezo film	8.00 (203.00)	7.50 (190.00)	11.00 (280.00)	10.50 (267.00)	40	Silver Ink	1-1004346-0	Fr. 217.00
52 μm piezo film	8.00 (203.00)	7.50 (190.00)	5.50 (140.00)	5.00 (127.00)	52	NiCu Alloy	2-1003703-4	Fr. 129.00
52 μm piezo film	8.00 (203.00)	7.50 (190.00)	11.00 (280.00)	10.50 (267.00)	52	NiCu Alloy	2-1003702-4	Fr. 257.00
52 μm piezo film	8.00 (203.00)	7.50 (190.00)	5.50 (140.00)	5.00 (127.00)	64	Silver Ink	2-1004347-0	Fr. 129.00
52 μm piezo film	8.00 (203.00)	7.50 (190.00)	11.00 (280.00)	10.50 (267.00)	64	Silver Ink	2-1004346-0	Fr. 257.00
110 μm piezo film	8.00 (203.00)	7.50 (190.00)	5.50 (140.00)	5.00 (127.00)	110	NiCu Alloy	3-1003703-4	Fr. 148.00
110 μm piezo film	8.00 (203.00)	7.50 (190.00)	11.00 (280.00)	10.50 (267.00)	110	NiCu Alloy	3-1003702-4	Fr. 296.00
110 μm piezo film	8.00 (203.00)	7.50 (190.00)	5.50 (140.00)	5.00 (127.00)	122	Silver Ink	3-1004347-0	Fr. 148.00
110 μm piezo film	8.00 (203.00)	7.50 (190.00)	11.00 (280.00)	10.50 (267.00)	122	Silver Ink	3-1004346-0	Fr. 296.00

Please contact factory for custom part quotations and volume pricing.

[Measurement Specialties, Inc.](#)

DT Series Elements

The DT series of piezo film sensors elements are rectangular elements of piezo film with silver ink screen printed electrodes. They are available in a variety of different sizes and thicknesses.

The DT film element produces more than 10 millivolts per microstrain, about 60 dB higher than the voltage output of a foil strain gage. The capacitance is proportional to the area and inversely proportional to the thickness of the element.

The DT series sensors are the simplest form of piezo film sensors, used primarily as dynamic strain gages and contact microphones for vibration or impact detection. These are available without any leads for those applications where the customer wants to make his own lead attachment. They can be readily adhered to a surface with double-sided tape or epoxy. Lead attachment can be achieved by compressive clamping, crimps, eyelets, conductive epoxy or low temperature solders.

DT elements are supplied with a thin urethane coating over the active sensor area; the lead attachment legs are free of the insulating urethane coating.

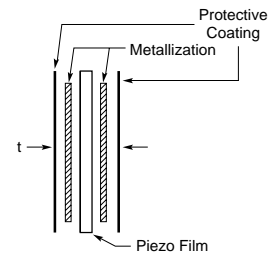
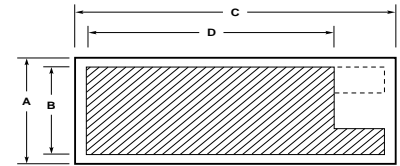

Dimensions in INCHES (mm)								Low Volume Price (SFr.)
Description (No Leads)	A Film	B Electrode	C Film	D Electrode	t (μm)	Cap (nF)	Part #	
DT1-028K	.64 (16.26)	.484 (12.29)	1.63 (41.40)	1.19 (30.17)	40	1.38	1-1002608-0	Fr. 2.00
DT1-052K	.64 (16.26)	.484 (12.29)	1.63 (41.40)	1.19 (30.17)	70	.740	2-1002608-0	Fr. 2.50
DT2-028K	.64 (16.26)	.484 (12.29)	2.86 (72.64)	2.42 (61.47)	40	2.78	1-1003752-0	Fr. 4.00
DT2-052K	.64 (16.26))	.484 (12.29)	2.86 (72.64)	2.42 (61.47)	70	1.44	2-1003752-0	Fr. 5.00
DT4-028K	.86 (21.84)	.740 (18.79)	6.72 (170.69)	6.13 (155.70)	40	11.00	1-1002149-0	Fr. 7.90
DT4-052K	.86 (21.84))	.740 (18.79)	6.72 (170.69)	6.13 (155.70)	70	5.70	2-1002149-0	Fr. 9.50

Please contact factory for custom part quotations and volume pricing.

DT Series Elements with Lead Attachment

The DT series of piezo film sensors elements are rectangular elements of piezo film with silver ink screen printed electrodes. They are available in a variety of different sizes and thicknesses.

Piezo film sensor elements are available with two lead attachment options. These include wires riveted to the film or wires attached to the film with eyelets. The eyelets offer holes at the lead attachment location to facilitate mounting.

The capacitance is proportional to the area and inversely proportional to the thickness of the element.

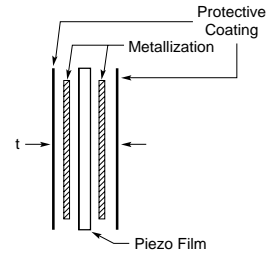
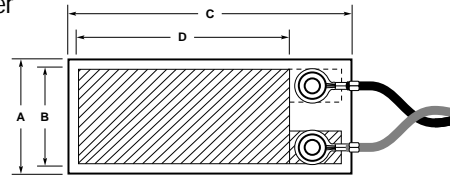

Dimensions in INCHES (mm)								Low Volume Price (SFr.)
Description	A Film	B Electrode	C Film	D Electrode	t (μm)	Cap (nF)	Part #	
DT1-028K/L w/rivets	.64 (16.26)	.484 (12.29)	1.63 (41.40)	1.19 (30.17)	40	1.38	1-1002908-0	Fr. 6.00
DT1-052K/L w/rivets	.64 (16.26)	.484 (12.29)	1.63 (41.40)	1.19 (30.17)	70	.740	2-1002908-0	Fr. 6.50
DT2-028K/L w/rivets	.64 (16.26)	.484 (12.29)	2.86 (72.64)	2.42 (61.47)	40	2.78	1-1003744-0	Fr. 7.90
DT2-052K/L w/rivets	.64 (16.26)	.484 (12.29)	2.86 (72.64)	2.42 (61.47)	70	1.44	2-1003744-0	Fr. 8.90
DT4-028K/L w/rivets	.86 (21.84)	.740 (18.79)	6.72 (170.69)	6.13 (155.70)	40	11.00	1-1002150-0	Fr. 11.90
DT4-052K/L w/rivets	.86 (21.84)	.740 (18.79)	6.72 (170.69)	6.13 (155.70)	70	5.70	2-1002150-0	Fr. 13.40

Please contact factory for custom part quotations and volume pricing.

LDT Series Elements with Lead Attachment and Lamination

The 'L' in LDT stands for 'laminated' sensor. Typically, a 0.005" (125 μm) polyester layer is laminated to a 28 μm or 52 μm piezo film element. When used in a 'bending' mode, laminated film elements develop much higher voltage output when flexed than non-laminated (i.e., DT series) elements. The piezo film is off the neutral axis in the laminate, and is strained more when flexed. Applications for this include

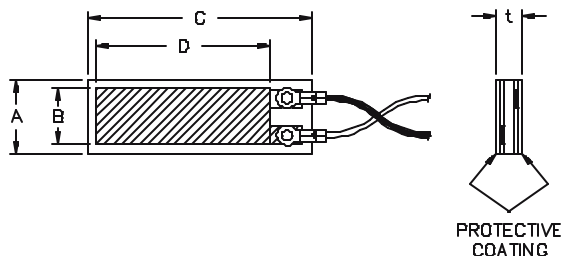

LDT Series with rivets and wire leads

beam-type vibration sensors for vehicle alarms and solid state switches for counters and momentary contact closure type switches. Piezo film sensor LDT elements are available in a variety of lead attachment options. The LDT0-028K has crimped-on pins, 0.200" on center, suitable for soldering. For significantly increased sensitivity, the LDTM-028K (M-Mass) combines an LDT0-028K form factor with the addition of a .72 gram round mass (located E (.14") from the edge on the opposite side of the crimps in the center of the A (.26") dimension.) The LDT1, 2 and 4 have 12" of 26 gauge twisted pair wire. The capacitance is proportional to the area and inversely proportional to the thickness of the element.

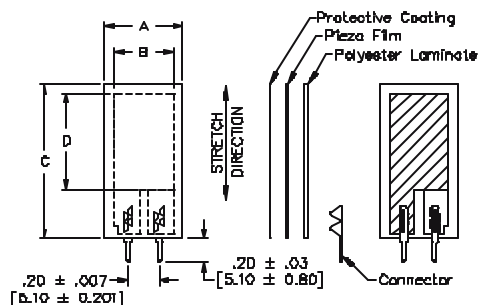

LDT0-028K (with crimped-on solder tabs)

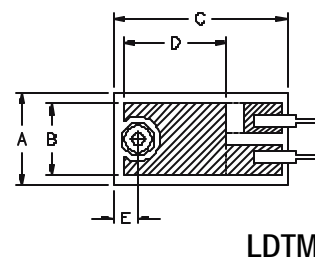

The LDT0-028K and LDTM-028K with solder tabs can be soldered directly to a PCB with a reasonable level of care. Piezo film cannot withstand high temperatures (> 80°C), and therefore soldering of the pins to a PCB must be done quickly. A heatsink clamped to the interface area between the film and the crimps will take the heat away from the film. Pre-tin the PCB and then quickly solder the sensor to the board. Do not allow the soldering iron to touch the film, and do not use a dwell time of over 5 seconds on the pins. Low temperature solders can also be used. For tightly tolerated sensitivity requirements, please consult MSI Sensors for techniques used to control variations of boundary conditions in production. Detailed specification sheets are available from our website.

Description	Dimensions in INCHES [mm]							Low Volume Price (SFr.)
	A Film	B Electrode	C Film	D Electrode	t (μm)	Cap (nF)	Part #	
LDT0-028K/L w/crimps	.520 [13]	.400 [10]	.980 [25]	.580 [15]	205	.500	0-1002794-0	Fr. 2.00
LDT1-028K/L w/rivets	.640 [16]	.484 [12]	1.63 [41]	1.19 [30]	205	1.38	1-1002910-0	Fr. 5.00
LDT2-028K/L w/rivets	.640 [16]	.484 [12]	2.86 [73]	2.42 [62]	205	2.78	1-1003745-0	Fr. 9.00
LDT4-028K/L w/rivets	.860 [22]	.740 [19]	6.72 [171]	6.13 [156]	205	11.0	1-1002405-0	Fr.15.00
LDTM-028K w/crimps	.520 [13]	.400 [10]	.980 [25]	.580 [15]	205	.420	0-1005447-1	Fr. 2.50

FDT Series Elements with Lead Attachment

The 'F' in FDT Series stands for 'Flexible Leads'. These are rectangular elements of piezo film with silver ink screen printed electrodes. Rather than making the lead attachment near the sensor, the piezo polymer tail extends from the active sensor area as flex circuit material with offset traces. This gives a very flat, flexible lead, with a connector at the end.

The FDT elements are available in a variety of different sizes and thicknesses. They are available without a laminate (FDT), with a laminate (0.005" mylar) on one side (FLDT) or with tape release layer adhesive (FDT with adh) in the sensor area.

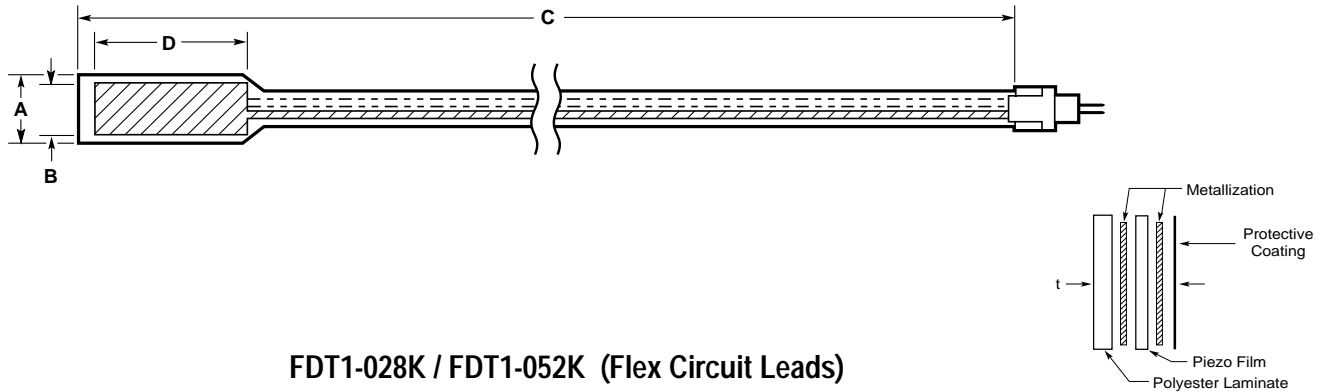

FDT1-028K / FDT1-052K (Flex Circuit Leads)

The connector pins on the FDT sensors can be directly soldered to a PCB with a reasonable level of care. This component cannot withstand high temperatures (>80°C), and therefore soldering of the pins to a PCB must be done quickly. A heatsink clamped to the interface area between the film and the crimps will take the heat away from the film. Pre-tin the pins and then quickly solder them to the board. Do not allow the soldering iron to touch the film, and do not use a dwell time of over 5 seconds on the pins. Low temperature solder can also be used. The FDT is also available with a connector for insertion onto standard .025" square pins.

Dimensions in INCHES (mm)								Low Volume Price (SFr.)
Description	A Film	B Electrode	C Film	D Electrode	t (µm)	Cap (nF)	Part #	
FDT1-028K	.620 (15.87)	.485 (12.31)	9.25 (235.10)	1.16 (29.62)	55	1.37	1-1002785-1	Fr. 8.90
FDT1-052K	.620 (16.87)	.485 (12.31)	9.25 (235.10)	1.16 (29.62)	85	.740	2-1002785-1	Fr. 9.90
FLDT1-028K	.620 (16.87)	.485 (12.31)	9.25 (235.10)	1.16 (29.62)	205	1.37	1-1002786-1	Fr. 8.90
FLDT1-052K	.620 (16.87)	.485 (12.31)	9.25 (235.10)	1.16 (29.62)	230	.740	2-1002786-1	Fr. 9.90
FDT1-028K w/adh-F	.650 (16.50)	.485 (12.31)	5.51 (140.00)	1.18 (30.00)	125	1.37	0-1001777-0	Fr. 8.90

Please contact factory for custom part quotations and volume pricing.

SDT Shielded Piezo Film Sensors Element with Shielded Cable

The 'S' in SDT Series stands for 'Shielded Sensor'. SDT1 piezo film sensors elements are rectangular elements of piezo film with silver ink screen printed electrodes. The sensor area is folded over on itself, giving a self-shielding of the transducer area. This is important in applications where 60 Hz EMI cannot be properly filtered, or in applications in a high EMI environment.

The SDT1 can be adhered to other surfaces using double sided adhesives, epoxy or cyanoacrylate (super-glue). Care should be taken if the sensor is to be removed, as the double-side adhesive can peel the metallization from the film.

When adhered to a surface in this manner, the SDT1 is an excellent contact microphone or dynamic strain gage. The output from the SDT1 can input directly to an oscilloscope or a signal analyzer. The low frequency roll off for the sensor is determined by the input impedance of the electronics. Typical impedances to be used would be at least 1 M Ω for most applications, and may need to be as high as 100 M Ω if 1-10 Hz frequencies are being monitored.

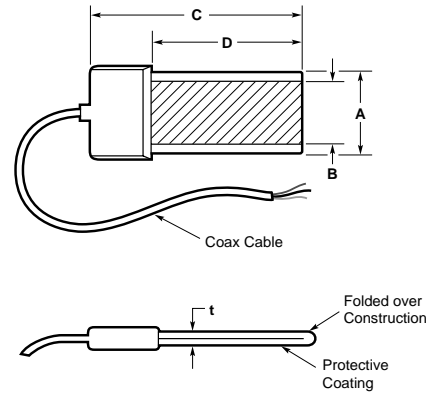

Dimensions in INCHES (mm)								Low Volume Price (SFr.)
Description	A Film	B Electrode	C Film	D Electrode	t (μ m)	Cap (nF)	Part #	
SDT1-028K	.644 (16.36)	.520 (13.21)	1.641 (41.00)	1.18 (30.00)	75	2.78	1-1000288-0	Fr. 49.30

Please contact factory for custom part quotations and volume pricing.

Piezo Polymer Thick Film Elements

Piezo film has typically been available in thin film (9 – 110 μm) formats. These are useful thicknesses for most applications. Over the past few years, extensive research has been done to produce thicker films and non-standard shapes for those specialized applications where very high sensitivity is needed in the thickness mode (d_{33}) or for hydrostatic (d_h) measurements, like sonar.

MSI has developed thick film elements of piezo polymer. The standard building block for this is 500 μm material, which can be multi-layer stacked for increased sensitivity. As the thickness of the series stacked sensor increases, the sensitivity increases, but the capacitance decreases proportionately.

Additional stacking options are available on a custom basis for parallel wired configurations, where elements of film are laminated and wired to give a higher capacitance per unit of surface area. This option can also be used in order to create a shielded transducer, or an acceleration canceling device. The piezo polymer thick film elements can be provided with aluminum electrodes which clamp the in-plane piezo coefficients and therefore increase the hydrostatic sensitivity. These elements can be fabricated to customer specification, and can be made in sizes up to 12" x 18".

Thick piezo polymer can also be supplied in a cylinder format, with a wall thickness of 1.07 mm. The inner and outer walls are metallized with silver ink for electrodes. Wires can be affixed to these electrodes with conductive epoxy. Please specify the length dimension of the cylinder sensor when ordering.



Description	Dimensions		Capacitance pF/in ² (pF/cm ²)	Sensitivity (dB, re 1 V/μPa)	Part No.	Low Volume Price (SFr.)
	Polymer Thickness	Overall Thickness				
500S Tile	.020	.040	88.90	-198.0	0-1001160-0	Fr. 49.30/in ²
	.500	.900	13.80			
1000S Tile	.040	.059	44.40	-192.0	0-1001155-0	Fr. 98.50/in ²
	1.00	1.50	6.90			
1500S Tile	.060	.079	29.60	-188.5	0-1001172-0	Fr. 147.80/in ²
	1.50	2.00	4.60			
Cylinder	.047	Diameter	41.00 pF/in	-195.0	0-1001911-1 (+) 0-1001911-2 (-)	Fr. 49.30 each
	1.10	.440 11.18	16.04 pF/cm			

NOTE: The (+) and (-) refer to the polarity

Please contact factory for custom part quotations and volume pricing.

[Measurement Specialties, Inc.](#)

Piezo Film Solid State Switches

Piezo film's capability to generate a high voltage output under bending strain, combined with its rugged form factor, make it an ideal candidate for solid state impact switches. Rather than using a switch contact closure, the piezo film generates a pulse which is detected by electronics. Although many of the DT's, LDT's and FLDT's supplied by MSI are used for switch applications, it is sometimes convenient to have a switch with integrated electronics.

The SW100 is an ideal configuration for impact detection and momentary switch applications. A direct contact force on the tip of the stainless steel cantilever beam of the SW100 induces strain on the laminated Piezo Film Sensor (PFS) element. With dynamic strain, the PFS element generates an output that activates a built-in, normally-open circuit. Once activated, the circuit resembles the closure of a contact switch, but without the inherent discontinuity that contact points exhibit because of corrosion, pitting and bouncing. Thus the SW100 provides a single digital pulse that is ideal for triggering digital circuits and signal processing. The imperviousness, elasticity and reliability of the PFS element, along with the noise rejection characteristics of the circuit, combine to provide the SW100 with features that suit applications demanding consistent, reliable performance throughout tens of millions of switching cycles.

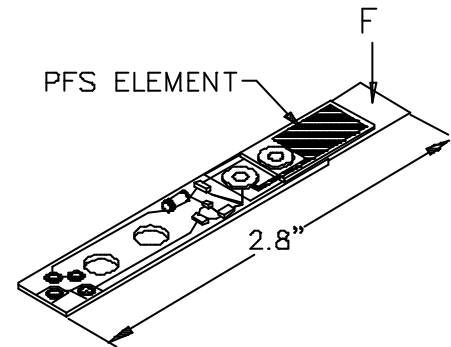

Smart Switch SW100

Custom options are available to fit specific customer applications. For more information on the SW100, please call one of our applications engineers. Detailed specification sheets are available from our website.

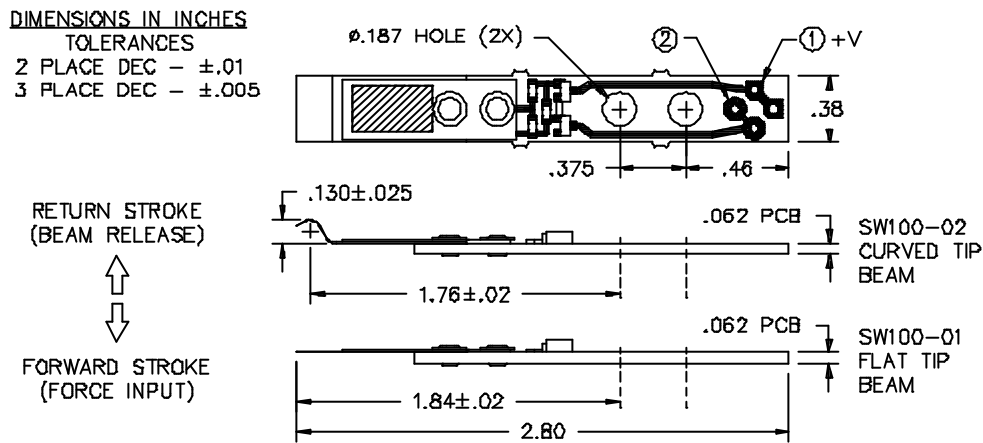

Description	Beam Tip	Stroke Direction to Trigger Switch	Part #	Low Volume Price (SFr.)
SW100-01-R	Flat	Reversed	0-1002393-1	Fr. 10.50
SW100-01-F	Flat	Forward	0-1002393-2	Fr. 10.50
SW100-02-R	Curved	Reversed	0-1002132-1	Fr. 10.50
SW100-02-F	Curved	Forward	0-1002132-2	Fr. 10.50

*Please contact factory for custom part quotations and volume pricing.

Piezo Polymer Coaxial Cable

Piezo cable is an alternative form of piezo polymer sensor. Designed as a coax cable, the piezo polymer is the "dielectric" between the center core and the outer braid. When the cable is compressed or stretched, a charge or voltage is generated proportional to the stress.

Piezo cable has a number of advantages in certain applications. Due to its coaxial design, the cable is self-shielded, allowing its use in a high EMI environment. The piezo cable can be spliced to passive coax, using standard coax splice techniques. It is extremely rugged, and will withstand repeated impacts. Its linear format makes it ideal for monitoring large areas which would be difficult and more expensive to do with piezo film.

Continuous lengths of piezo cable is available in a variety of different gages and construction formats. As a standard product, it is offered as a 20 AWG center core with a polyethylene outer jacket

We offer two versions of the piezo cable:

able from our website.

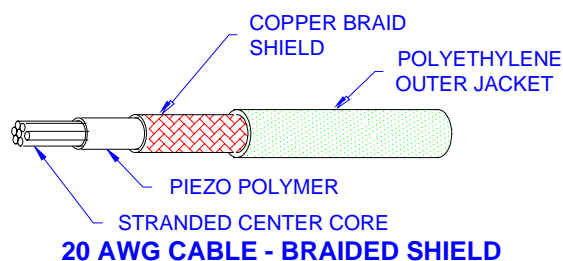

20 AWG CABLE - COPOLYMER or 20 AWG CABLE - SPIRAL WRAP

Description	Dimensions (Nom)		Capacitance pF/Foot (Nom) [pF/Meter]	Part No.	Price per meter (SFr.)
	Center Core	Outside Dia.			
20 AWG Piezo Cable	.040 [1]	.107 [3]	200 [655]	0-1005646-1	SFr. 33.00 (1-500 meters)*
20 AWG Piezo Cable - spiral wrap construction	.040 [1]	.105 [3]	279 [980]	0-1005801-1	SFr. 26.00 (1-500 meters)*

*Please contact factory for custom part quotations and volume pricing.

Measurement Specialties, Inc.

Traffic Sensors

The **Roadtrax** BL Traffic Sensor is designed for Permanent or Temporary installation into or onto the road surface for the collection of traffic data. The unique construction of the sensor allows it to be installed directly into the road in a flexible format so that it can conform to the profile of the road. The flat construction of the sensor gives an inherent rejection of road noise due to road bending, adjacent lanes, and bow waves for approaching vehicles. The small cut in the road minimizes the damage that is done to the road, speeds up the installation and reduces the amount of epoxy that is used for the installation. The Roadtrax BL sensor is available both as a Class I sensor for the highest level of uniformity needed for Weigh in Motion applications and as a Class II sensor which is more cost effective for Counting, Classifying, High speed Toll Booths, Speed Detection, and Red Light Cameras.

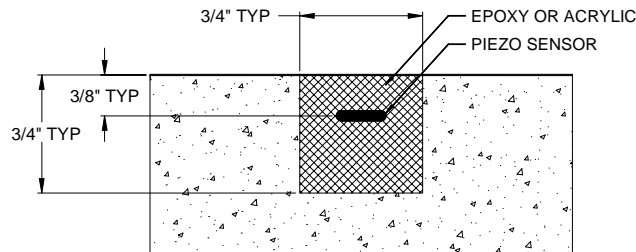

Permanent In-The-Road Installation

- Uniform, **high amplitude** piezoelectric output **compatible with existing** counters and classifiers on the market.
- Excellent Signal to Noise Ratio which has an inherent **10:1 rejection** of road noise due to road bending, adjacent lanes and bow waves of approaching vehicles.
- Easy installation in a 3/4" x 3/4" slot, which minimizes the disturbance of the road, decreases the depth of the road cut, and minimizes the amount of epoxy needed.
- Flexible sensor - conforms to any road profile while maintaining a uniform distance to the road surface.
- The **final installation is flush** with the road surface - snowplows will not do damage to the sensor.
- Durable enough to withstand normal installation handling and **hundreds of millions ESAL's**.
- All sensors are **100% tested and certified** for performance as a complete sensor prior to shipment.
- Custom Passive Signal Cable with **High Density Polyethylene Jacket** which is rated for direct burial and resists nicks and cuts.

Description	Part #	Price (SFr.) (Qty 1-49)
6' BL Class II w/100'	0-1005333-1	Fr. 590.00
8' BL Class II w/100'	1-1005333-1	Fr. 707.00
10' BL Class II w/100'	3-1005333-1	Fr. 825.00
11' BL Class II w/100'	4-1005333-1	Fr. 884.00
12' BL Class II w/100'	5-1005333-1	Fr. 943.00
6' BL WIM	1-1005438-1	Fr. 1118.00
8' BL WIM	2-1005438-1	Fr. 1342.00
10' BL WIM	4-1005438-1	Fr. 1566.00
11' BL WIM	5-1005438-1	Fr. 1678.00
12' BL WIM	6-1005438-1	Fr.1790.00
Extra Cable (50' increments only)	0-1004552-0	Fr. 1.00/ft

For additional information, request [Roadtrax Traffic Sensors Catalog](#).

Interface Circuit Board for Piezoelectric Traffic Sensor

The Traffic Sensor Interface Board is designed to condition signals from MSI's piezoelectric traffic sensors to interface with a wide variety of industry standard traffic data collection modules. The Traffic Sensor Interface Board contains six channel sensor signal conditioning circuitry, user adjustable comparator, digital pulse output, and internal power regulation. The Interface Board can be powered from a single supply voltage between +8VDC and +28 VDC.

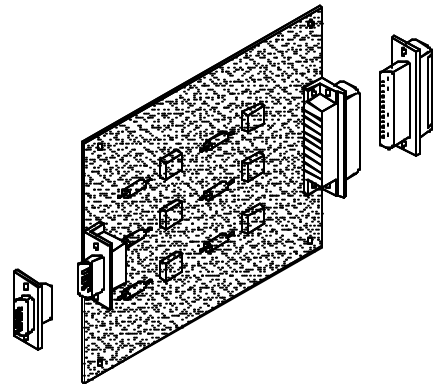

SPECIFICATIONS

Number of input/output channels	6
Input (Analog)	9 Pin D type Male Connector
Output (Digital)	25 Pin D type Male Connector
Circuit Board Size	220mm x 128mm
Front Panel	50mm x 128mm
Storage Temperature	-40°C ~ +85°C
Operating Temperature	-40°C ~ +70°C

Output Connector Pin Assignment		Input Connector Pin Assignment	
Pin #	Assignment	Pin #	Assignment
1	GND	1	CH6
2	Power Supply	2	CH5
3	Not Used	3	CH4
4	Digital Output (CH1)	4	CH3
5	Digital Output (CH2)	5	CH2
6	Digital Output (CH3)	6	CH1
7	Digital Output (CH4)	7	GND
8	Digital Output (CH5)	8-9	Not Used
9	Digital Output (CH6)		
10-25	Not Used		

Description	Part #	Low Volume Price (SFr.)
Interface Circuit Board for Piezoelectric Traffic Sensor	0-1005766-0	Fr. 598.00

Measurement Specialties, Inc.

15 MAY 01
Page 13 of 24

Interface Circuit Board for Piezoelectric Traffic Sensor (cont'd)

SPECIFICATIONS (cont'd)

Analog Circuit				
	Min	Typ	Max	Unit
Dynamic range	25		3V	mV
Gain		2		
Lower cutoff frequency (-3dB)		0.5		Hz
Upper cutoff frequency (-3dB)		1,200		Hz
Power Supply	+8		+28	VDC

Digital Output				
	Min	Typ	Max	Unit
Output Impedance			10k	ohms
Pulse output	4.5	5	5.5	V
Pulse width, t_w	2.8	3.3	3.8	ms
Black-out time, t_b	8.5	10.0	11.5	ms

Trip Level		
Dip Switch Position	V_{trip}	Unit
All Off	0.05	V
1 On	0.1	V
2 On	0.2	V
3 On	0.4	V
4 On	0.8	V

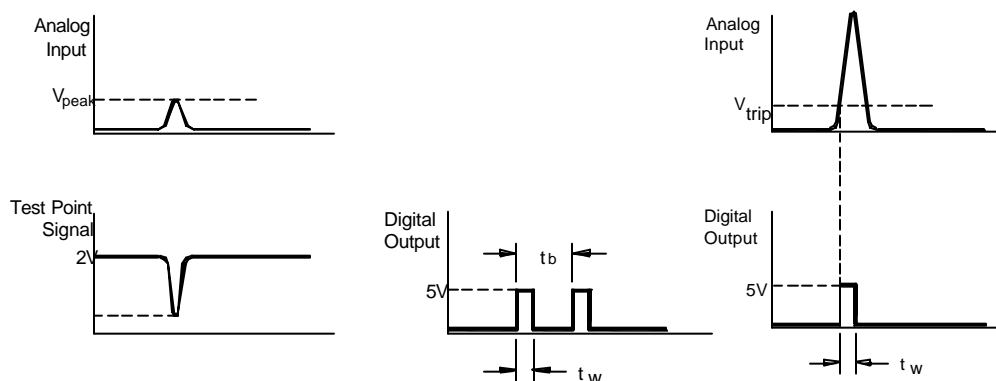

NOTE: V_{trip} indicates the sensor voltage output to trigger digital output.

NOTE: Test point signal has -2X gain and +2V DC offset.

Measurement Specialties, Inc.

15 MAY 01
Page 14 of 24

Accelerometers

The MSI family of accelerometers addresses a wide range of application needs. The ACH-01 is a general purpose, low cost, linear single axis accelerometer for a variety of monitoring applications. The ACH-04-08-05 is a multi-axis accelerometer, and the ACH-04-08-09 is a single-axis accelerometer, both with integrated buffer electronics designed for PCB mounting applications.

The MSI family of accelerometers have opened new doors to the design engineer who needs to continuously monitor vibration, shock and acceleration. Detailed specification sheets are available from our website.

MSI Accelerometers			
	Applications	Features	Benefits
ACH-01-XX	? Car alarms ? Motional feedback for speakers ? Integrated motor vibration monitor ? Appliance vibration monitoring ? Shipping damage recorder ? Musical instrument pickups	? Low cost ? Very low power ? Single axis ? Wide frequency response ? Large dynamic range ? Small, lightweight ? Buffered electronic output	? High performance/price ratio ? Low impedance output for simplified user interface ? Very rugged to reduce failures ? Ability to easily measure high frequency events ? Low noise - High output
ACH-04-08-05	? Disk drive shock sensor ? Appliance vibration monitoring ? Automotive applications ? Security sensors	? Very low cost ? Very low power ? Multiple axis response, each as an independent channel ? Small size - PCB mountable ? Integrated buffer electronics ? Low corner frequency	? Exceptional performance at a very low cost ? Buffered output lowers noise, reduces user interface electronics ? Measures acceleration in multiple axes with only one sensor
ACH-04-08-09	? Car alarms ? Appliance vibration monitoring ? Security sensors ? Low cost embedded applications	? Very low cost ? Very low power ? Single axis ? Integrated buffer electronics ? Small size - PCB mountable ? Low frequency response	? Excellent performance at very low cost ? Buffered output lowers noise, reduces user interface electronics ? High sensitivity with very low power

Accelerometers

Production Qualified Accelerometers				
		ACH-01-XX	ACH-04-08-05	ACH-04-08-09
Key Features		-Wide Frequency Range -Wide Dynamic Range -High Sensitivity -Low Noise -JFET Buffer	-Low Frequency Operation -3 Simultaneous Analog Outputs -Low current generation - JFET Buffer	-Low Frequency Operation -Low Current Operation - JFET Buffer
Sensitive Axes	X-Axis	---	X	--
	Y-Axis	---	X	X
	Z-Axis	X	X	--
Sensitivity (Nominal)		10 mV/g	1.8 mV/g	6mV/g
Frequency Range (± 3 dB)		1.0 Hz-20 kHz	0.5 Hz to 4 kHz	0.2 to 1500 Hz
Dynamic Range		± 250 g	± 250 g	± 40 g
Resolution (@ 100 Hz)		$40 \mu\text{g}/\sqrt{\text{Hz}}$	$200 \mu\text{g}/\sqrt{\text{Hz}}$	$40 \mu\text{g}/\sqrt{\text{Hz}}$
Resonant Frequency		>35 kHz	9.2 kHz	3.4 kHz
Resonant Q (Hz/Hz)		30	10	10
Transverse Sensitivity		5%	15%	<20%
Linearity		0.1%	0.1%	0.1%
Operating Temperature		-40 °C to +85 °C	-40 °C to +85 °C	-40 °C to +85 °C
Storage Temperature		-40 °C to +85 °C	-40 °C to +85 °C	-40 °C to +85 °C
Maximum Shock		1000 g	1000 g	1000 g
Supply Voltage		3 V to 40 V	3 V to 40 V	3 V to 28 V
Supply Current		2 μ A Typical	6 μ A Typical	2 μ A Typical
Weight		3 grams	0.35 grams	0.35 grams
Size (mm)		13 x 19 x 6	11 x 10 x 1.8	11 x 10 x 1.8
Mounting Method		Adhesive	Hand Solder to PCB	Hand Solder to PCB

ACH-01 (General Purpose)

The ACH-01 is an inexpensive, very robust, general purpose accelerometer with outstanding performance characteristics. The use of KYNAR Piezo Film in the ACH-01 provides many cost/performance advantages that allow it to be used in a wide range of applications where the use of traditional accelerometer technology is impractical. It is specifically designed for high volume applications which require the permanent installation of an accelerometer, such as machine health monitoring, modal analysis, automotive sensors, appliances, and feedback control systems.

FEATURES

- ? Wide Frequency Response
- ? Excellent Phase Response
- ? Wide Temperature Range
- ? Wide Dynamic Range
- ? Small Temperature Dependence
- ? Low Cost
- ? Large Supply Voltage Range
- ? Excellent Linearity
- ? Low Impedance Output
- ? Very High Resonance
- ? Electrically Isolated Base
- ? Low Mechanical Q
 - Low transverse sensitivity

Note: All dimensions in inches and are reference.

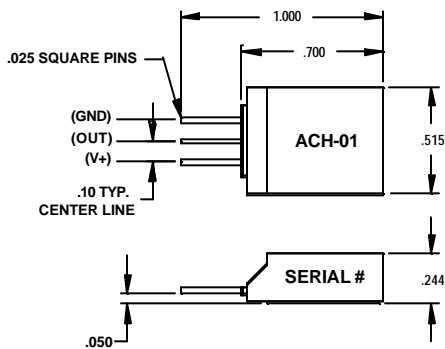

ACH-01-02 with Pins

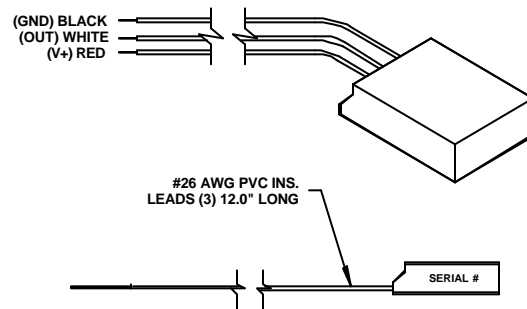

ACH-01-04 with Wires

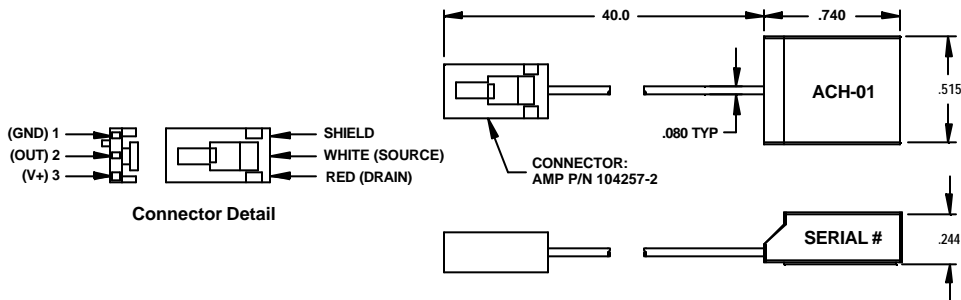

ACH-01-03 with Shielded Cable

Please contact factory for custom part quotations and volume pricing.

Description	Cable Configuration	Part #	Low Volume Price (SFr.)
ACH01-02/10	3 Pins, .25" square	0-1000985-0	Fr. 40.00
ACH-01-03/10	40" coax cable with female connector	1-1001220-0	Fr. 40.00
ACH-01-04/10	Wires	1-1001497-0	Fr. 40.00

ACH-04-08-05 (Multi-Axis)

The ACH-04-08-05 accelerometer contains three piezoelectric sensing elements oriented to simultaneously measure acceleration in three orthogonal, linear axes. Internal JFET's provide for a low impedance, buffered output with a wide variety of possible, application specific, signal conditioning circuitry. The sensor responds over a broad frequency range, from below 0.5Hz to above 5kHz, as a result of the integrated electronics and the damped sensing elements.

The ACH-04-08-05 accelerometer can be used in a wide range of applications including motional measurement and control systems, speaker feedback systems, vibration switches, shipment monitor and material handling systems, security systems, computer input/output devices, and data loggers. The device is not IR reflow solderable.

FEATURES:

- ? Fully Contained 3-Axis Accelerometer
- ? Low Frequency Response
- ? High Resonant Frequency & Low Q
- ? Excellent Linearity
- ? Three Simultaneous Analog Outputs
- ? Low-Impedance Output
- ? Ultra-Low Power
- ? Low Cost

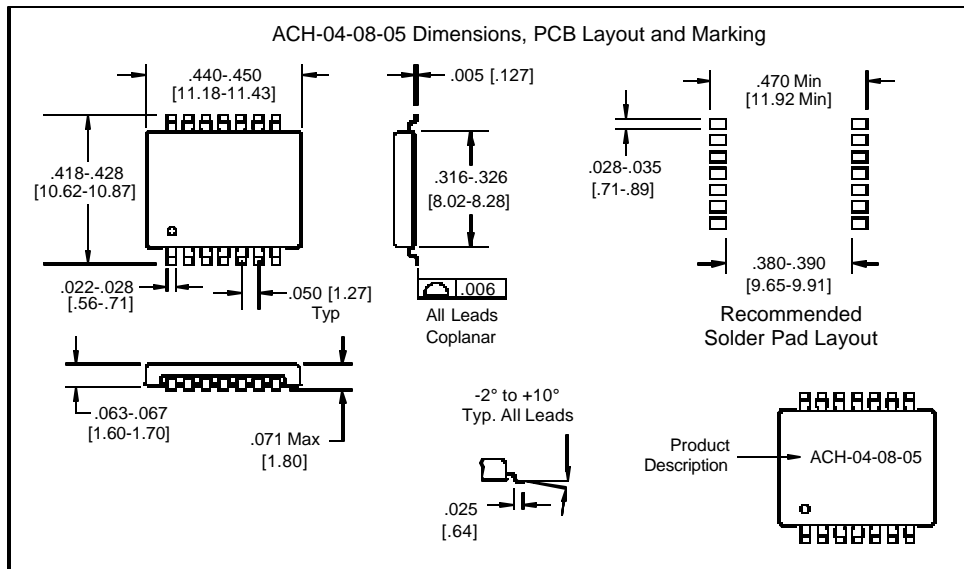
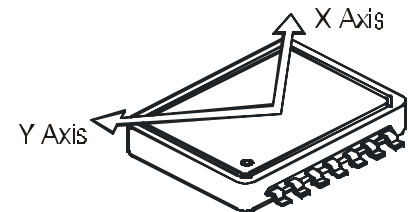
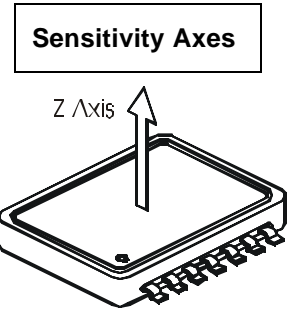

Description	Part #	Low Volume price (SFr.)
ACH-04-08-05	0-1003800-5	Fr. 50.00

Please contact factory for custom part quotations and volume pricing.

Measurement Specialties, Inc.

ACH-04-08-09 (Single Axis)

The ACH-04-08-09 accelerometer contains a single mass loaded piezoelectric sensing element oriented to measure acceleration in the plane of the device. An internal JFET provides for a low impedance, buffered output allowing a wide variety of off chip application specific signal conditioning circuitry. The sensor responds over a broad frequency range, from below 0.5Hz to above 2kHz, as a result of the integrated electronics and the damped sensing elements.

The ACH-04-08-09 accelerometer can be used in a wide range of applications including motion measurement and control systems, speaker feedback systems, vibration switches, shipment monitor and material handling systems, security systems, computer input/output devices, and data loggers.

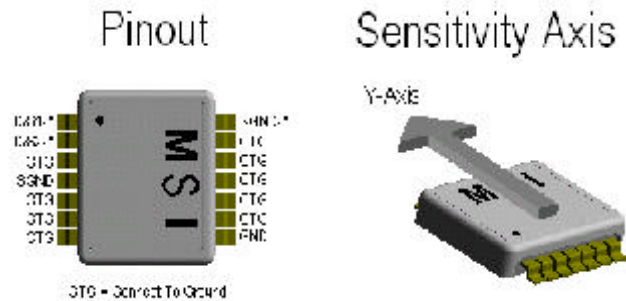

FEATURES:

- Fully Contained Single Axis Accelerometer
- Low Frequency Response
- Single Buffered Analog Output
- Low-Impedance Output
- Low Q at Resonance
- Excellent Linearity
- Ultra-Low Power (Typical I_o of 4mA)
- Low Cost

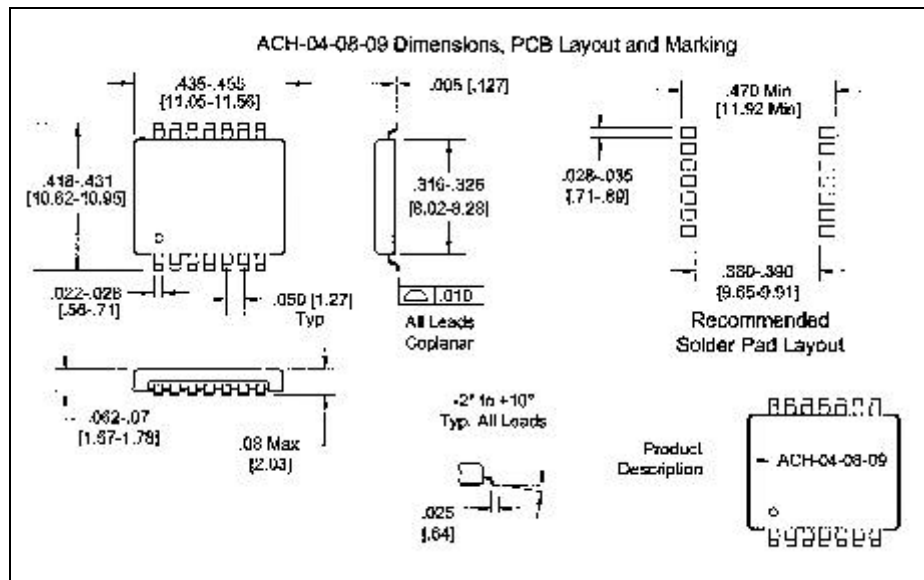

Description	Part #	Low Volume price (SFr.)
ACH-04-08-09	0-1005755-1	Fr. 50.00

Not for new product developments. Please contact factory for availability and volume pricing.

Measurement Specialties, Inc.

IB-ACH01 (Amplifier Box)

MSI has developed this low cost interface amplifier specifically for use with the ACH-01. It is designed to mate directly to the connector supplied with the ACH-01-03 assembly. For use with either the ACH-01-02 or ACH-01-04, an adapter is required to interface the two components.

Characteristics	IB-ACH-01
Gain	10 X
Low Frequency Filter	-3dB @ 2 Hz, fixed
High Frequency Filter	-3dB @ 30 kHz, fixed
Power Supply	One 9 Volt Battery
Input Interface	FET for ACH-01
Supply Current	4.0 mA
Battery Life	80 Hours
Low Battery Cutoff	7.2 V
Output Impedance	100 Ω
Output Connector	BNC

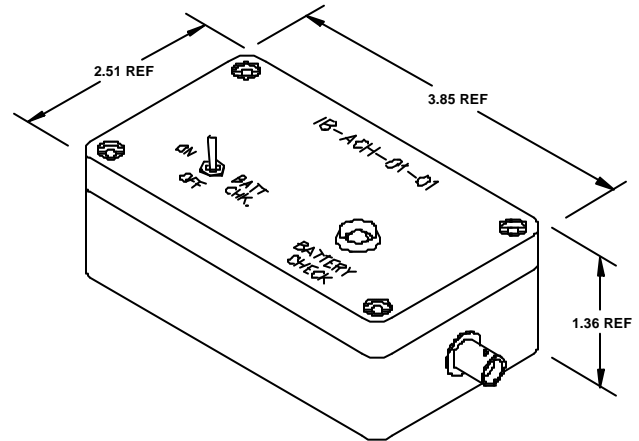

Description	Part #	Low Volume Price (SFr.)
IB-ACH-01	0-1003058-0	Fr. 198.00

Please contact factory for custom part quotations and volume pricing.

ACH-04-08-05 Analog Test PCB

The ACH04-08-05 Accelerometer Analog Test PCB provides a simple way to evaluate the ACH-04-08-05 three-axis accelerometer. The unit consists of the ACH-04-08-05 accelerometer, a low-power operational amplifier, along with passive resistors and capacitors to provide signal conditioning. The sensor and circuit are preassembled on a double-sided, printed circuit board with three feet of flexible cable for easy user interface. The system demonstrates the basic capabilities of the ACH-04-08-05 accelerometer. Detailed specification sheets are available from our website.

FEATURES:

- Signal Conditioned 3-Axis Accelerometer
- High-Pass Filter @ 0.34Hz
- Low-Pass Filter @ 185Hz
- Requires Only Single +5V Power Supply
- Three Simultaneous Analog Outputs
- Low-Impedance Output
- Integrated Thermal Shield
- Ultra-Low Power (13µA @ 5V)

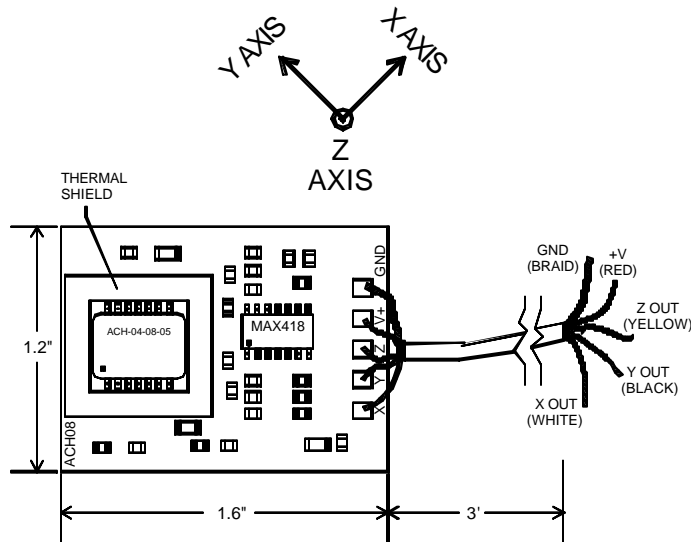

Description	Part #	Low Volume price (SFr.)
ACH-04-08-05 Analog Test PCB	0-1005685-1	Fr. 100.00

Please contact factory for custom part quotations and volume pricing.

40kHz Omni Directional Ultrasound Transmitters 40kHz Wide Angle Ultrasound Receivers

Piezoelectric film (PVDF) ultrasound transmitters and receivers offer unique advantages for air ranging applications. Cylindrical 40kHz PVDF transmitters exhibit omni-directional horizontal beam directivity and broad band characteristics.

Cylindrical 40kHz PVDF receivers exhibit very wide horizontal beam directivity and broad band characteristics. These characteristics lend unique solutions in many applications such as two-dimensional positioning, digitizer, object detection, and distance measurement.

Depending on the applications, resonance frequency and vertical beam directivity of the transmitter and receiver can easily be customized by changing the diameter and length of the PVDF cylinder. The receiver has a very wide horizontal beam angle and it can be reduced by changing the housing design if necessary.

PVDF transmitters and receivers also have very low resonance Q value. Typically, PVDF transmitters have a Q value of 5 and PVDF receivers have a Q value of 4 This means that the rising time and the signal decay time are much faster than the conventional ceramic transmitters. This characteristic is suitable for high speed data acquisition or high speed digitizer applications.

A test board, consisting of snap-in mounting holes and test pins, is available for easy evaluation of the 40kHz transmitters. A preamplifier is available for easy evaluation of the 40kHz receivers.

FEATURES:

- Omni-directional horizontal beam directivity
- Broad band
- Low resonance Q
- Excellent impact resistance
- Low cost
- Light weight

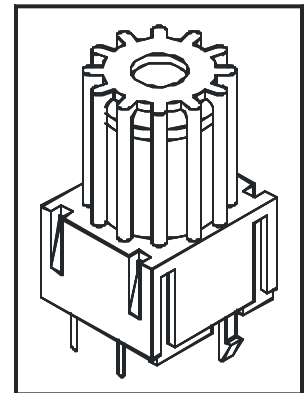

Description	Part #	Low Volume Price (1 - 9) (SFr.)
40 kHz <u>Transmitter</u>	1005853-1	Fr. 20.00
Test Board (for <u>Transmitter</u>)	1005854-1	Fr. 20.00
Drive Electronics (for <u>Transmitter</u>)	1005855-1	Fr. 200.00
40kHz <u>Receiver</u>	1005856-1	Fr. 20.00
Preamplifier Board (for Receiver)	1005857-1	Fr. 50.00

Please contact factory for custom part quotations and volume pricing.

Measurement Specialties, Inc.

15 MAY 01
Page 22 of 24

Shockwriter 3000®

The Shockwriter 3000 is a portable event recorder which monitors the environmental conditions during transportation and records specific events which exceed user defined standards. The combination of a triaxial accelerometer and thermistor provide the capability to accurately record vibration (shock) in any axes simultaneously as well as temperature. All recorded information is stored with the commensurate date including hour and minutes for easy possession tracking.

The unit is designed with a great deal of flexibility such that the end user can program the specific operating conditions based upon their specific application. The unit is easily programmed by a simple menu driven setup screen through an RS-232 serial interface port and a host computer (portable PC). In addition, the unit can be reprogrammed at any time in the future if the application or environmental conditions merit different monitoring thresholds.



Some of the specific operating parameters programmed by the end user include: temperature monitoring thresholds and intervals; acceleration thresholds and duration of event; sleep mode power conservation; data storage priority sorting and arming method. The most significant vibration events will contain additional information that will allow the user to graph the information (all three axes) or save it for further processing including signature analysis or statistical process control.

FEATURES

- ? Measures shock in three axes simultaneously, as well as temperature extremes, with commensurate date and time
- ? Password protected memory and setup configuration
- ? Permanent memory of data (even with loss or interruption of power)
- ? User friendly menu driven software programmed via RS232 port, DOS compatible or Windows95
- ? Lightweight (2.5lbs); slim profile
- ? Battery powered with long life power saving options
- ? Over 700 separate total events can be recorded
- ? Significant events can be easily graphed or transferred to more familiar software packages
- ? Fast software prevents Shockwriter from missing events
- ? Reusable for many different applications
- ? Affordable

For additional information, request the [Shockwriter Catalog](#).

APPLICATIONS

- ? Continuation of ISO 9000 practices throughout transit
- ? Detection of events that may cause hidden damage (before installation begins)
- ? In-house materials handling / production monitoring
- ? Military hardware - certificate of transportation
- ? Aerospace hardware - certificate of transportation
- ? Insurance claim assistance
- ? Machinery monitoring
- ? Packaging optimization
- ? Air cargo quality
- ? International ocean transportation
- ? Railroad car coupling events

Description	Part #	Low Volume Price (SFr.)
Shockwriter Kit (contains Shockwriter, software, power pack, data cable)	0-1005204-1	Fr. 2'680.00
Data Cable (additional)	0-1005118-1	Fr. 166.00
Power Pack (additional)	0-1005117-1	Fr. 156.00

KITS:

A good way to learn more about piezo film sensors is to purchase one of our design kits. These kits illustrate the use of piezo film in different configurations, and are a good starting point to learn more about piezo film sensors and their applications.

Basic Design Kit: This kit demonstrates the use of MSI piezo film sensors as microphones, speakers, switches and acoustic pickups. All the components and film samples in the kit can be used for experimentation.

Contents of the Basic Design Kit:

- ? Technical Manual
- ? Speaker Element
- ? Piezo Cable
- ? Flicker
- ? SW100-01-F
- ? ACH04-08-05
- ? SDT1-028K
- ? DT0-028K
- ? LDT1-028K
- ? DT1-028K
- ? Test PCB ACH-04-08 (w/o Analog circuit)
- ? Application Notes
- ? Application Specs
- ? Instruction Sheets

Piezo Cable Kit: This kit features MSI piezo polymer in coaxial cable format. Piezo cable is especially useful for large area sensing applications such as physical security and safety mat sensors, proximity sensors, traffic sensors and security fence transducers.

Contents of the Piezo Cable Kit:

- ? Technical Manual
- ? Application Specs
- ? 20 AWG Piezo Cable spliced to RG-174/U with BNC Connector

Vibration and Acceleration Kit: This kit demonstrates the capabilities of piezo film as a vibration sensor and accelerometer component. The kit includes shielded and unshielded thin film sensors and an ACH-01 accelerometer component with an interface amplifier.

Contents of the Vibration and Acceleration Kit:

- ? Technical Manual
- ? SDT1-028K
- ? ACH-01 MSI Box
- ? ACH01-03/10
- ? LDT1-028K
- ? LDT0-028K
- ? DT1-028K
- ? 9 Volt Battery
- ? Application Specs
- ? Instruction Sheets

Ultrasound Design Kit (40KHz): This kit demonstrates the basic design concept of ultrasonic digitizers and distance measurements. Since piezo film ultrasound transducers have low Q values and very wide beam directivities, it is perfect for high resolution position detection applications. The kit includes transmitters, receivers, and interface electronics.

Contents of the Ultrasound Design Kit:

- ? Four 40KHz transmitters
- ? Four 40KHz receivers
- ? One drive electronic circuit board
- ? Two preamplifiers
- ? Two test boards
- ? Cable assemblies
- ? Product data sheets and an instruction sheet

Description	Part #	Price (SFr.)
Basic Design Kit	0-1004308-0	Fr. 266.00
Piezo Cable Kit	0-1003726-0	Fr. 197.00
Vibration/Acceleration Kit	0-1003460-0	Fr. 372.00
Ultrasound Design Kit	0-1005870-1	Fr. 395.00

Measurement Specialties, Inc.